



YOUR RADIO CONNECTED
AROUND THE **WORLD**

FM18KS/E

FM 18KW TRANSMITTER



BT Broadcast Transmitters

25 years developing and producing radio transmitters
integrating technology and innovation.



FM18KS/E

FM 18KW TRANSMITTER

GET TO KNOW OUR TRANSMITTERS EQUIPMENTS

Developed with state-of-the-art technology, the new FM18KS/E of 18kW Premium Series FM transmitters are revolutionary in their category.

With innovative concepts, the BT transmitters allow the user to integrate with the world wide web through the new HTML interface.

Designed with LDMOS technology, the BT transmitters offer excellent performance that translates into electricity savings.

Built in aluminum and with external finish in stainless steel, besides the beautiful appearance, they present a reduced weight.

- Excellent finish throughout the equipment;
- Coaxial cables with Teflon dielectric and silver conductors;
- Structure in stainless steel and aluminum perfectly fitted and screwed;



IoT Internet of things

HTML connectivity

HTML interface with fixed IP for each transmitter allowing the user free access to the equipment from any point with the Internet.



IoT - Internet of Things



LDMOS Technology



Finishing and Ruggedness



100% Brazilian product

+ 55 51 3368-5470

+ 55 51 9 9731 8235

vendas@btonline.com.br

BT Broadcast Transmitters

BT Broadcast Transmitters

@btbroadcasting



FM18KS/E FM 18KW TRANSMITTER

TRANSMITTER CHARACTERISTICS

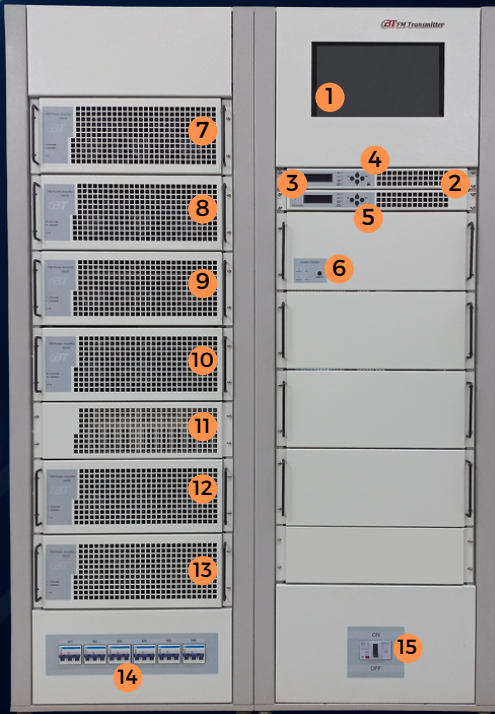

1. 13,3" touch screen HTML main display;
2. Control modules 1 and 2;
3. Auxiliary displays of the control modules;
4. Auxiliary navigation keys of the control modules;
5. Auxiliary USB connectors of the control modules;
6. Selector for control modules 1 and 2;
7. Module 1 - 3,5kW Amplifier
8. Module 2 - 3,5kW Amplifier;
9. Module 3 - 3,5kW Amplifier;
10. Module 4 - 3,5kW amplifier;
11. Unbalanced load
12. Module 5 - 3,5kW amplifier;
13. Module 6 - 3,5kW amplifier;
14. Thermo magnetic circuit breakers of the amplifiers;
15. Thermo magnetic circuit breaker main;

AMPLIFIER MODULES

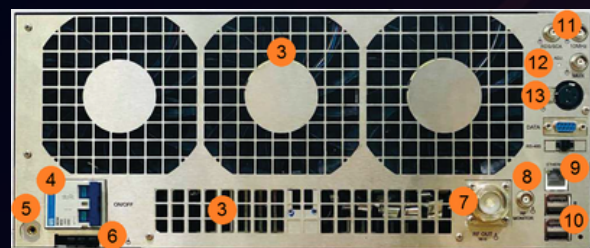

1. Module Fasteners
2. LEDs Operating status;
3. Air passage;
4. Protection circuit breaker;
5. Grounding system connection;
6. AC power connector
7. Module power output
8. RF monitor connector
9. Interconnectivity access;
10. USB Peripherals;
11. External 10MHz sync input;
12. Modulation attenuator;
13. Input signal connection;



- Separation and shielding between transmitter stages;
- Coaxial cables with Teflon dielectric and silver conductors;
- Mechanical parts in aluminum perfectly fitted and screwed;
- The RF boards are produced with a Teflon-based substrate and plated with ENIG (nickel-gold alloy) which, in addition to durability and thermal stability, presents a low electrical resistance minimizing undesirable losses;

+ 55 51 3368-5470

+ 55 51 9 9731 8235

vendas@btonline.com.br

BT Broadcast Transmitters

BT Broadcast Transmitters

@btbroadcasting

AMPLIFIER BLOCK DIAGRAM

The block structure allows a simple way to have an idea of the distribution of the parts of each module. The LD MOS amplifier provides 1000W in its output and has as a highlight the output power control that is made from the voltage variation of the PS3003D source over the power supply of the RF amplifier drains programmed via the transmitter's CPU.

We emphasize this detail, which we consider important, because each module can vary its output power from values close to zero up to its nominal power, ensuring high and stable performance in the output stage, even at low programmed powers.

We also highlight the fan rotation control that is commanded by the existing temperature sensors. Thus, in less hot environments, the fans work with lower rotation, ensuring greater energy savings and longer life for the entire set.

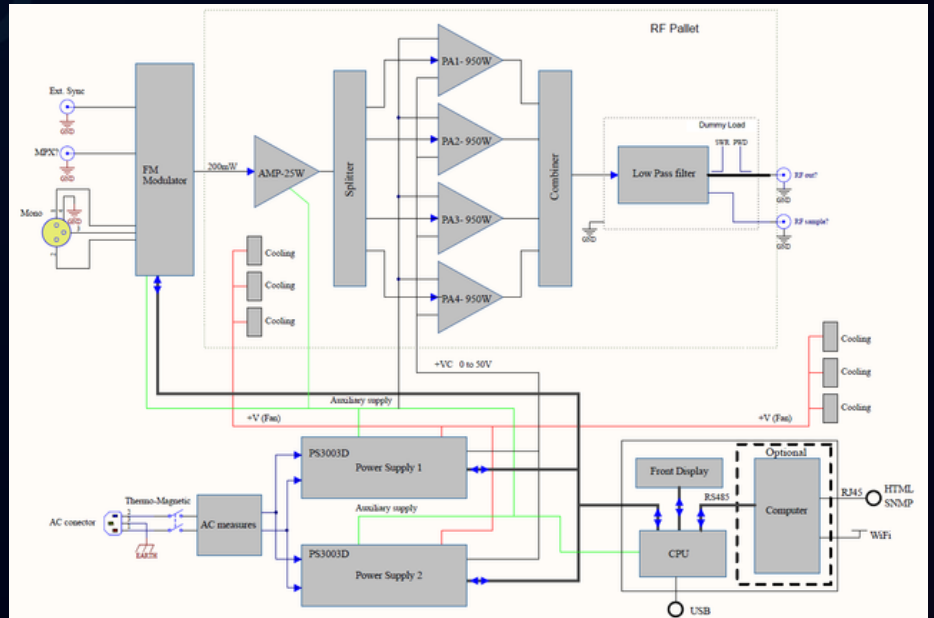

TRANSMITTER BLOCK DIAGRAM

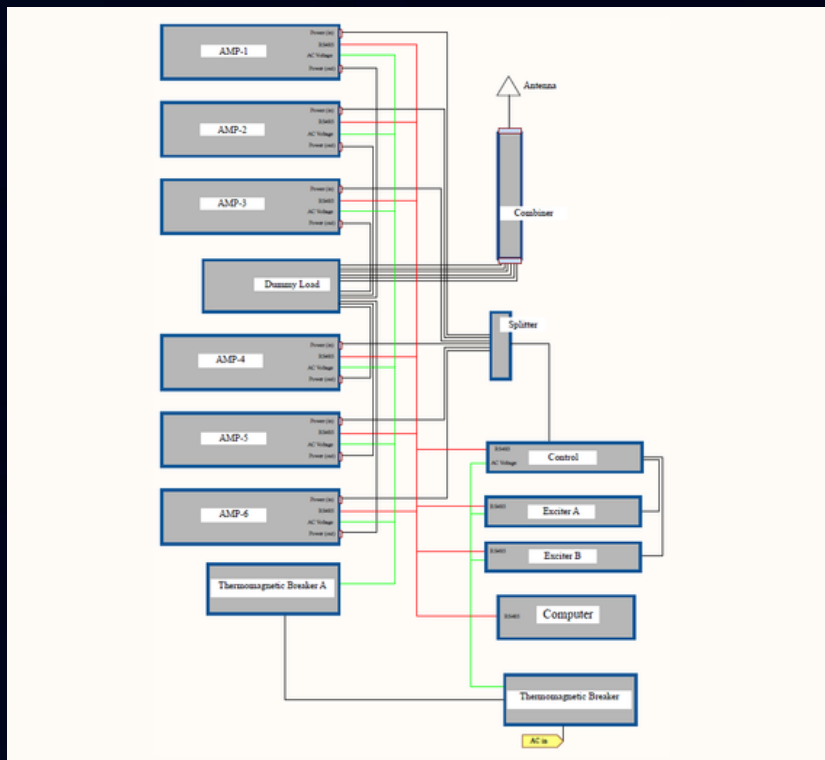

Formed by six 3,500W amplifiers combined, they provide more than 18,000W at their output operating synchronized by the control module that generates the low power RF signal for each amplifier.

The computer on top, besides all the programming and control, is also responsible for the interconnectivity of the transmitter with the outside world by having a LAM interface, RJ-45 connector, and WiFi access.

Below the amplifiers is the unbalance load and the primary AC distributor with the protective circuit breakers. The unbalance load comes into play when one of the modules is removed for maintenance or for some reason the power of each module is different from the others.



FM18KS/E

FM 18KW TRANSMITTER

SAVE MORE ENERGY

You can have significant electricity savings by reducing the power of your transmitter during periods when it is not interesting to maintain high power, for example, during the early morning.



Its FM transmitter does all this automatically without the need for an operator.



Attitudes that make all the difference

+ 55 51 3368-5470

+ 55 51 9 9731 8235

vendas@btonline.com.br

BT Broadcast Transmitters

BT Broadcast Transmitters

@btbroadcasting



FM18KS/E

FM 18KW TRANSMITTER

TECHNICAL SPECIFICATIONS

AC LINE PARAMETERS

Power supply with $\pm 10\%$ tolerance: 3 phase - 220V/380V AC input voltage
Frequency: 50 / 60Hz $\pm 5\%$
Power factor: 0,98 (with power factor corrector - PFC)
Nominal power consumption: < 26 kW
Overall efficiency: $\geq 72\%$

RF PARAMETERS

RF Carrier frequency range: 76,1 MHz - 87,5 MHz (FM9KOE Model)
87,7 MHz - 107,9 MHz (FM9KOS Model)
Emission: Monophonic 180K F3EGN
Stereophonic 256K F8EHF
Stereophonic + secondary chain 340K F8EWF
Digital DRM e HD Radio®

Frequency stability with ambient temperature
between 0°C and +50°C: $\leq \pm 200$ Hz (with local oscillator)
Adjustable output power: 0,05 to 19,8 kW
Modulation deviation: ± 150 kHz (max)
Range Attenuation: $\leq \pm 0,1$ dB
Spurious and Harmonics: ≤ -80 dBc

AUDIO PARAMETERS

Audio frequency range: 20 Hz - 15 kHz
Basic band frequency range (MUX): 20 Hz - 200 kHz
Audio response to frequencies 50Hz to 15kHz: According to the pre-emphasis drops of 25, 50 and 75 μ s (programmable)
Total distortion at audio frequencies in the range 50 to 15,000 kHz for 25, 50 and 100% modulation: $\leq 0,1\%$
Frequency modulation noise level in the range 50 Hz to 15 kHz relative to 100% modulation on 400 Hz signal: ≤ -60 dB
Amplitude modulation noise level in the range 50 Hz to 15 kHz with respect to 100% modulation: ≤ -70 dB

ACCESS CONNECTORS

Output antenna connector RF (RF Out): EIA 3 1/8" 50 Ω
Monitor frequency connector (RF Monitor): BNC 50 Ω
10 MHz Synchronism (Sync 10MHz): BNC 50 Ω
MONO (L): XLR 600 Ω
Composite signal (MUX): BNC 10 k Ω
Connectivity: Touch screen 13,3" - HTML Interface
Universal Serial Bus (USB)

OPTIONS

Pilot (Pilot): BNC 50 Ω
stereo (L + R) XLR 600 Ω
AES / EBU: XLR 110 Ω
RDS / SCA: BNC 50 Ω
Connectivity: SNMP

PHYSICAL DIMENSIONS

Height: 1780 mm
Width: 1186mm
Depth: 1023mm
Weight (kg): 310 kg